



Clean Energy Systems, Inc.

Summary
January 2005

www.cleanenergysystems.com

Clean Energy Systems, Inc. (CES) has developed zero-emissions fossil-fueled power generation technology, integrating proven aerospace technology into conventional power systems. The core of CES' process involves replacing steam boilers and flue gas cleaning systems with "gas generator" technology adapted from rocket engines. The gas generator burns a combination of oxygen and a gaseous hydrocarbon fuel to produce a mixed gas of steam and carbon dioxide at high temperature and pressure, which powers conventional or advanced steam turbines. High efficiencies are obtained for utility-sized power plants, but without any atmospheric emissions. Possible fuel sources include renewable biomass, natural gas, or coal syngas, and the cycle is a net producer of water when air cooled condensers are used.

From the turbines, the steam/CO₂ exhaust gas is cooled, separating into its components, water and CO₂, with the latter either sold or stored. The gas generator technology has been used successfully in aerospace applications for decades, including in the Space Shuttle Main Engines, where hydrogen and oxygen are combusted to produce pure steam at high temperature and pressure. Likewise, high-temperature, high-pressure turbines have been used successfully in aerospace applications. Every other component in the CES process is commercially proven and is standard in power generation or other industries.

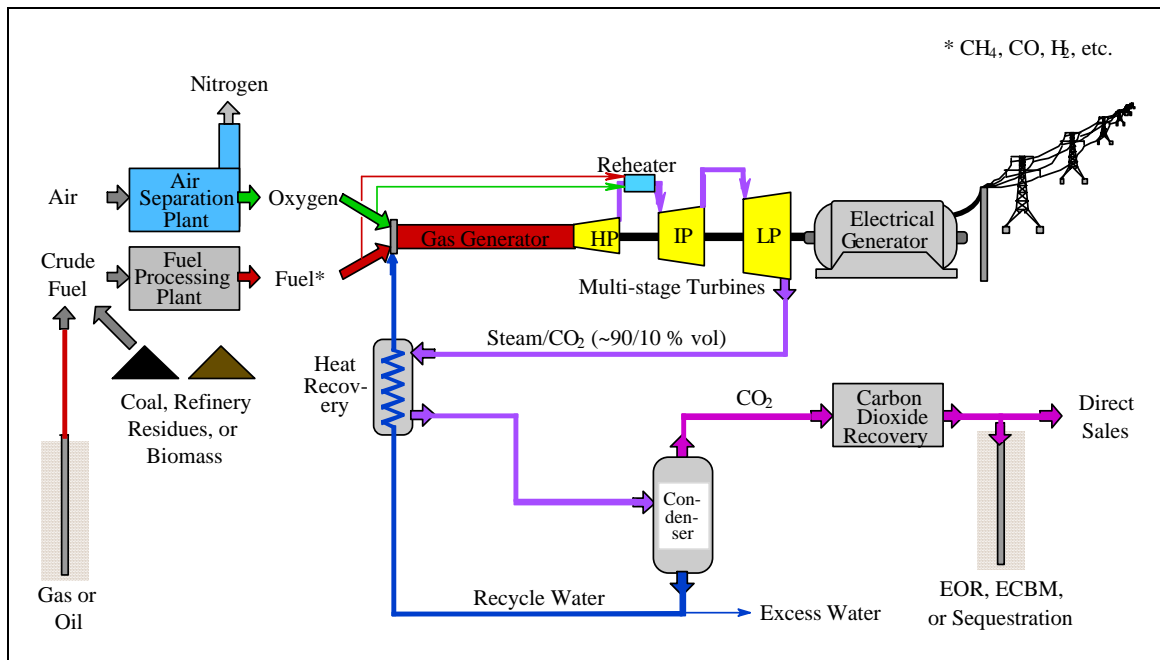

The CES Process

CES' objective is to apply gas generators and high-temperature, high-pressure turbines from aerospace applications to power generation, much like the process by which aircraft jet engines were adapted for aeroderivative turbines in conventional power plants.

Achievements of the company include:

Technology Protection

- CES has 17 issued patents and more than 30 pending applications, domestic and foreign.

“Proof of Concept” Prototype

- In 2000 CES proved its concept with a 110 kW pilot project at the University of California, Davis, with co-funding provided by the California Energy Commission (CEC).

10 MW Gas Generator

- US DOE awarded CES a \$2.5 million grant under the Vision 21 Program to design and build a 10 MW gas generator. CES has built and successfully tested its 20 MW_{th}, 10 MW_e unit.

Demonstration Project

- The CEC awarded CES \$4 million in funding to design and build a Demonstration Plant using CES technology. Major corporations Mirant and Air Liquide are participants, along with the US Department of Energy. In August 2003 CES acquired a 5 MW idle biomass plant, which has been repowered as a multi-fuel zero emission plant. Initial tests will be conducted with natural gas, with coal or biomass in subsequent phases. Operation of the power plant began in 2004, with operational tests of nearly three hours duration completed.

Commercial Applications

- Funded feasibility studies are currently underway for 50 MW zero-emission plants in Norway and the Netherlands. Projects are also under development in the United States. Investment decisions on these “first generation” zero emission plants are expected in 2005.

Other Government Support

- CES has obtained support from several government agencies, including the federal Department of Energy, National Laboratories in the DOE family, and the California Energy Commission. DOE has received \$3.7 million from defense sources for zero emission technology engineering. During 2002, close to \$1 million of this money was used to design, fabricate and test an inter-turbine gas reheater, to be employed in conjunction with the CES gas generator technology to maximize turbine efficiencies in CES concept power plants. Reheater testing was done by NASA, at its Plum Brook facility in Sandusky OH.

CES technology works with today’s turbines to produce power without pollution. The first generation power plants will have energy cost structures comparable to or below those of other clean energy sources, such as wind and solar power. With the introduction of the advanced turbines following these first generation plants, CES technology will ultimately operate at efficiencies similar to combined cycle plants without carbon capture.

There are no exhaust gases to be cleaned, and no emissions of sulfur oxides, nitrogen oxides, carbon dioxide, mercury, or other pollutants.



CES 20 MW_t Gas Generator

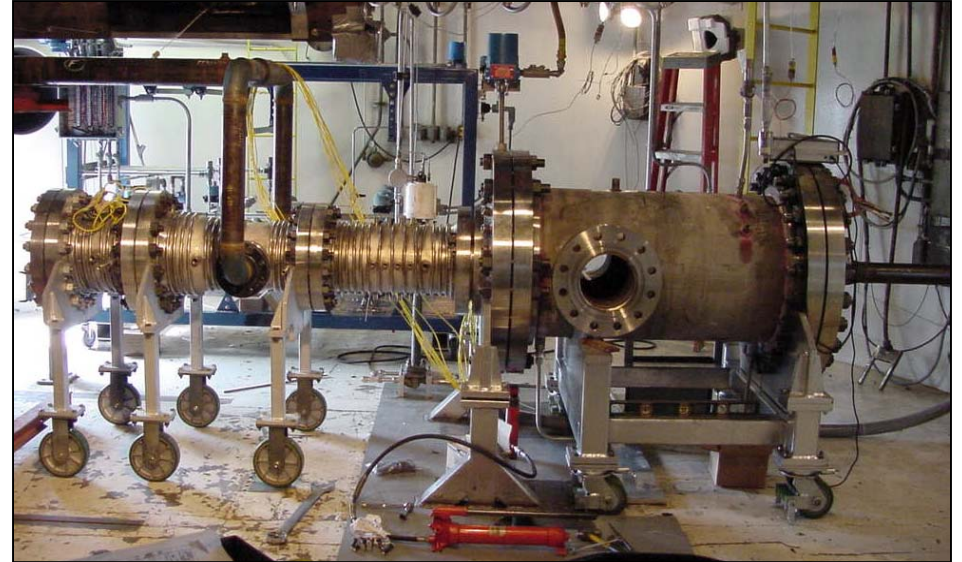

Reheater for CES System (designed by DOE- NASA tested)



CES 20 MW_t Gas Generator – 1500 psi & 1500 °F

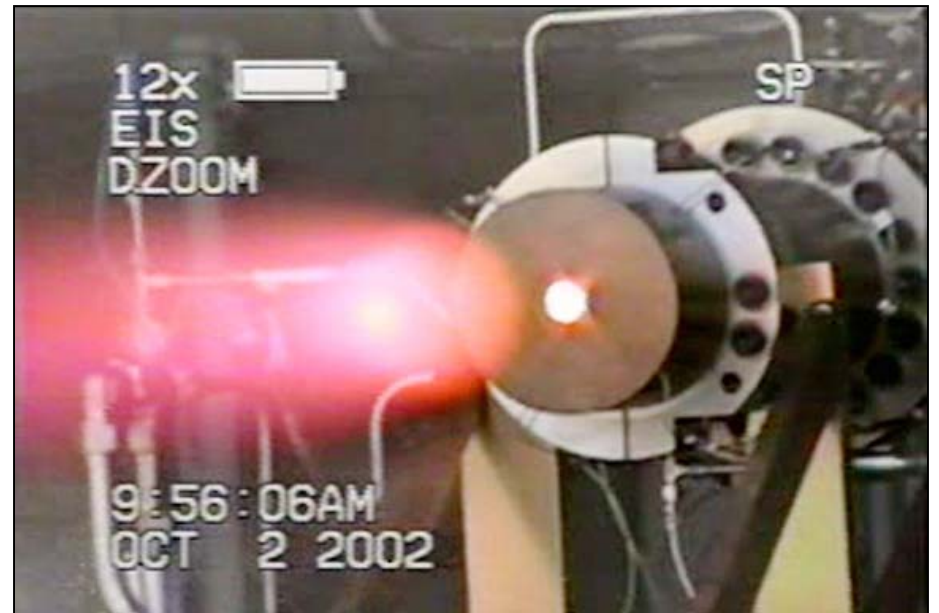

CES 20 MW_t Gas Generator – 1500 psi & 3000 °F

5 MW Multi-Fuel Testing Facility – Bakersfield, California USA
(venting the Steam/CO₂ drive gas – oxygen plant to the left)



5.5 MW Steam Turbine and Generator